

Dual USB Dedicated Charging Port Controller

Description

The MB5102 is a Dual USB dedicated charging port controller. An auto-detect feature monitors USB data line voltage, and automatically provides the correct electrical signatures on the data lines to charge compliant devices among the following dedicated charging schemes:

Divider DCP, required to apply 2.7 V and 2.7 V on the D+ and D- Lines respectively

BC1.2 DCP, required to short the D+ Line to the D- Line

Chinese Telecom Standard YD/T 1591-2009 Shorted Mode, required to short the D+ Line to the D- Line

1.2 V on both D+ and D- Lines

Features

- Supports USB DCP Shorting D+ Line to D- Line per USB Battery Charging Specification, Revision 1.2 (BC1.2)
- Supports Shorted Mode (Shorting D+ Line to D-Line) per Chinese Telecommunication Industry Standard YD/T 1591-2009
- Supports USB DCP Applying 2.7 V on D+ Line and 2.7 V on D- Line
- Supports USB DCP Applying 1.2 V on D+ and D- Lines
- Automatically Switch D+ and D- Lines Connections for an Attached Device
- Operating Range: 4.5 V to 5.5 V
- Available in SOT23-6 Package

Applications

- Car Charger
- Vehicle USB Power Chargers Networking Systems
- Other USB Chargers

Typical Application

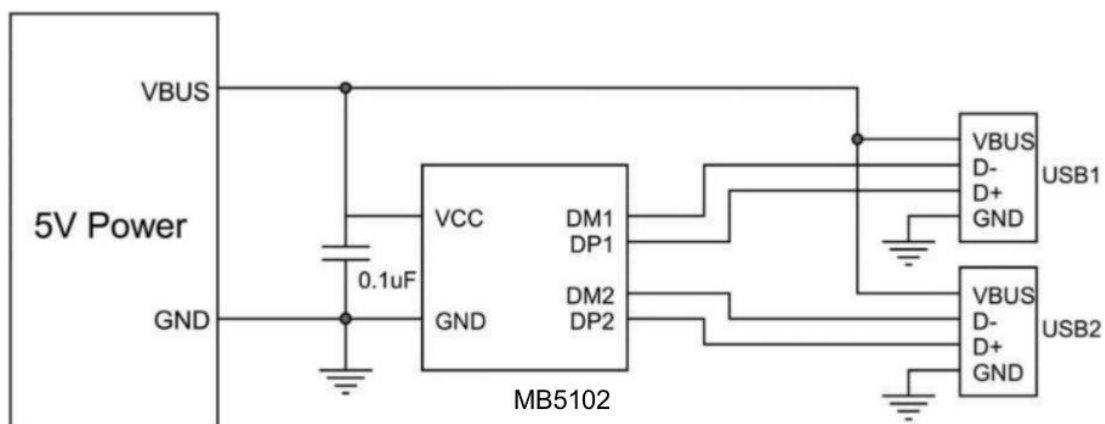

Absolute Maximum Ratings (at TA = 25°C)

Characteristics	Symbol	Rating	Unit
VIN to GND		-0.3 to 7	V
DP1,DM1,DP2,DM2 to GND		-0.3 to +6	V
Operating Junction Temperature		-40 to 125	°C
Storage Junction Temperature		-55 to 150	°C
Junction to Ambient Thermal Resistance	R ^θ JA	180	°C/W
Junction to board thermal resistance	R ^θ JB	120	°C/W
Junction to case thermal resistance	R ^θ JC	42	°C/W

ESD Ratings

		Value	Unit
Electrostatic discharge	Human-body model (HBM)	± 8000	V

Pin Function And Descriptions

PIN	NAME	Description
1	DP1	Connected to the D+ line of USB connector
2	GND	Ground
3	DP2	Connected to the D+ line of USB connector
4	DM2	Connected to the D- line of USB connector
5	VCC	Power supplier
6	DM1	Connected to the D-line of USB connector

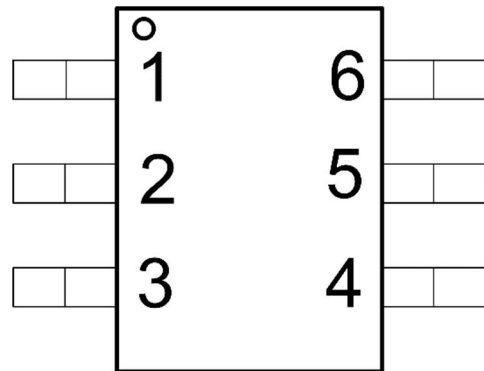

Order information

Order Information	Top Marking
NDP5102SE	NYWW (N: Part NO. Y:Year. WW:Week.

Recommended Operating Conditions

	Symbol	MIN	MAX	Unit
Input voltage of VCC	VCC	4.5	5.5	V
DP1,DP2 data line input voltage	VDP	0	5.5	V
DM1,DM2 data line input voltage	VDM	0	5.5	V
DP1,DP2 Continuous sink or source current	IDP	0	± 10	mA
DM1,DM2 Continuous sink or source current	IDM	0	± 10	mA



Electrical Characteristics

T_J = 25°C. VCC = 5V, unless otherwise noted

Characteristics	Symbol	Conditions	Min	Typ	Max	Units
Input Voltage	VCC		4.3	5	5.5	V
UVLO Voltage	V _{UVLO}		3.1	3.7	4.3	V
UVLO Hysteresis				0.1		V
Quiescent Current	I _{CCQ}	VCC=5V	-	220	-	uA
BC 1.2 DCP Mode						
DP,DM Short Resistance	R _{DPM}			160	200	Ω
Resistance between DPx and GND	R _{DPG}	VDPx=0.8V		650	1000	KΩ
Resistance between DMx and GND	R _{DMG}	VDMx=0.8V		650	1000	KΩ
DPx threshold of Goes to divider mode	V _{DPX_TH}			300		mV
Divider Mode						
DPx output voltage	V _{DPX_2.7}		2.6	2.7	2.8	V
DMx output voltage	V _{DMX_2.7}		2.6	2.7	2.8	V
DPx output impedance	R _{DPX}		24	30	36	KΩ
DMx output impedance	R _{DMX}		24	30	36	KΩ
1.2V /1.2V Mode						
DPX output voltage	V _{DPX_1.2}		1.12	1.2	1.28	V
DMX output voltage	V _{DMX_1.2}		1.12	1.2	1.28	V

Note: DPX Stands for DP1 or DP2, DMX Stands for DM1 or DM2

Block Diagram

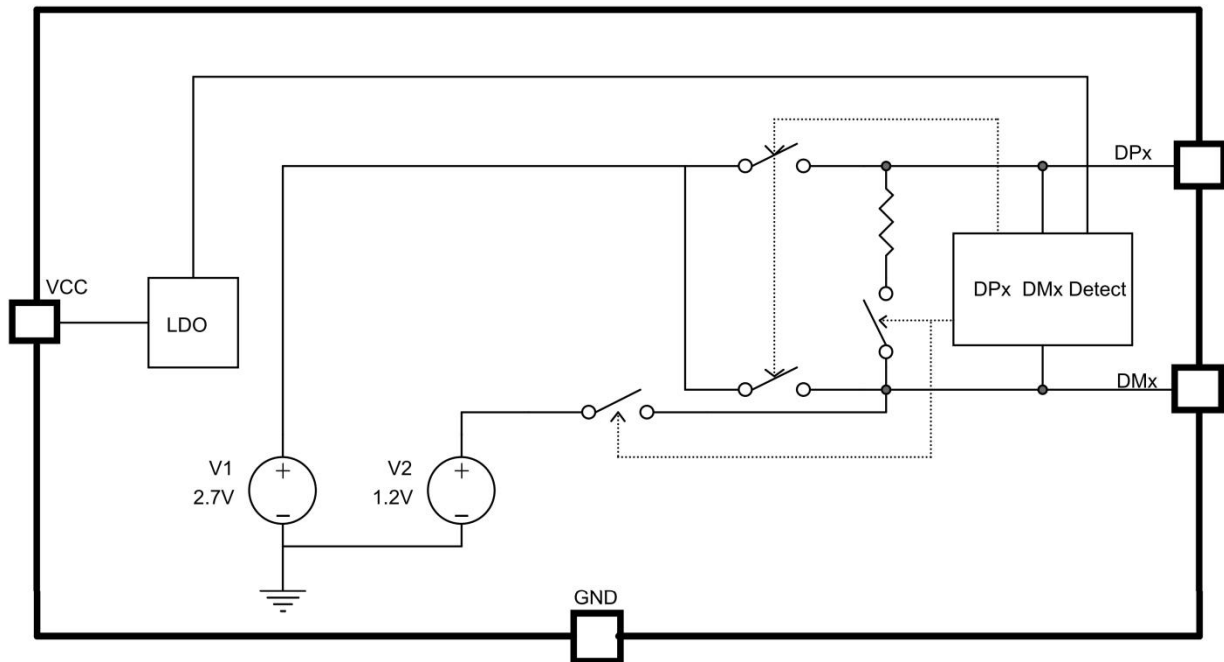

Operation

As USB charging has gained popularity, the 500mA minimum defined by USB 2.0 specification or 900mA defined in USB 3.0 specification, has become insufficient for many tablets and handphone which have a higher rated charging current. Several new standards have been introduced defining protocol handshaking methods that allow host and client devices to acknowledge and draw additional current beyond the USB 2.0 Specification and the USB 3.0 Specification while using a single USB input connector.

The MB5102 support four of the most common protocols:

- USB Battery Charging Specification, Revision 1.2 (BC1.2)
- Chinese Telecommunications Industry Standard YD/T 1591-2009
- Divider mode
- 1.2 V on both D+ and D- lines

YD/T 1591-2009 is a subset of the BC1.2 specification supported by the vast majority of devices that implement USB charging. Divider and 1.2-V charging schemes are supported in devices from specific yet popular device makers. BC1.2 has three different port types, listed as Standard downstream port (SDP), Charging downstream port (CDP) and Dedicated charging port (DCP)

The BC1.2 Specification defines a charging port as a downstream facing USB port that provides power for charging portable equipment. The BC1.2 Specification defines the protocol necessary to allow portable equipment to determine what type of port it is connected to so that it can allot its maximum allowable current drawn. The hand-shaking process is two steps. During step one, the primary detection, the portable equipment outputs a nominal 0.6-V output on its D+ line and reads the voltage input on its D- line.

The portable device concludes it is connected to a SDP if the voltage is less than the nominal data detect voltage of 0.3 V. The portable device concludes that it is connected to a Charging Port if the D– voltage is greater than the nominal data detect voltage of 0.3 V and less than 0.8 V. The second step, the secondary detection, is necessary for portable equipment to determine between a CDP and a DCP. The portable device outputs a nominal 0.6-V output on its D– line and reads the voltage input on its D+ line. The portable device concludes it is connected to a CDP if the data line being remains is less than the nominal data detect voltage of 0.3 V. The portable device concludes it is connected to a DCP if the data line being read is greater than the nominal data detect voltage of 0.3 V and less than 0.8 V.

Applications Information

Dedicated Charging Port (DCP)

A dedicated charging port (DCP) is a downstream port on a device that outputs power through a USB connector but is not capable of enumerating a downstream device, which generally allows portable devices to fast charge at their maximum rated current. A USB charger is a device with a DCP, such as a wall adapter or car power adapter. A DCP is identified by the electrical characteristics of its data lines. The following DCP identification circuits are usually used to meet the handshaking detections of different portable devices.

Short the D+ Line to the D– Line

The USB BC1.2 Specification and the Chinese Telecommunications Industry Standard YD/T 1591-2009 define that the D+ and D– data lines must be shorted together with a maximum series impedance of 200 Ω.

Divider DCP

The Divider charging scheme is used for 12-W adapters, and applies 2.7 V on D+ and D– lines.

Applying 1.2 V to the D+ Line and 1.2 V to the D– Line

The devices are USB dedicated charging port (DCP) controllers. Applications include vehicle power charger, wall adapters with USB DCP and other USB chargers. The device DCP controllers have the auto-detect feature that monitors the D+ and D– line voltages of the USB connector, providing the correct electrical signatures on the DP and DM pins for the correct detections of compliant portable devices to fast charge. These portable devices include smart phones, 5-V tablets and personal media players.

DCP Auto-Detect

The devices integrate an auto-detect feature to support divider mode, short mode and 1.2 V / 1.2 V modes. If a divider device is attached, 2.7 V is applied to the DPx and DMx pin. If a BC1.2-compliant device is attached, the MB5102 automatically switches into short mode. If a device compliant with the 1.2 V / 1.2 V charging scheme is attached, 1.2 V is applied on both the DP pin and the DM pin. default mode is Divider 3 (D+/D– = 2.7 V / 2.7 V).

Undervoltage Lockout (UVLO)

The undervoltage lockout (UVLO) circuit disables DP1, DM1, DP2 and DM2 output voltage until the input voltage reaches the UVLO turn on threshold. Built-in hysteresis prevents unwanted oscillations due to input voltage drop from large current surges.

Package Description

SOT23-6 (unit: mm)

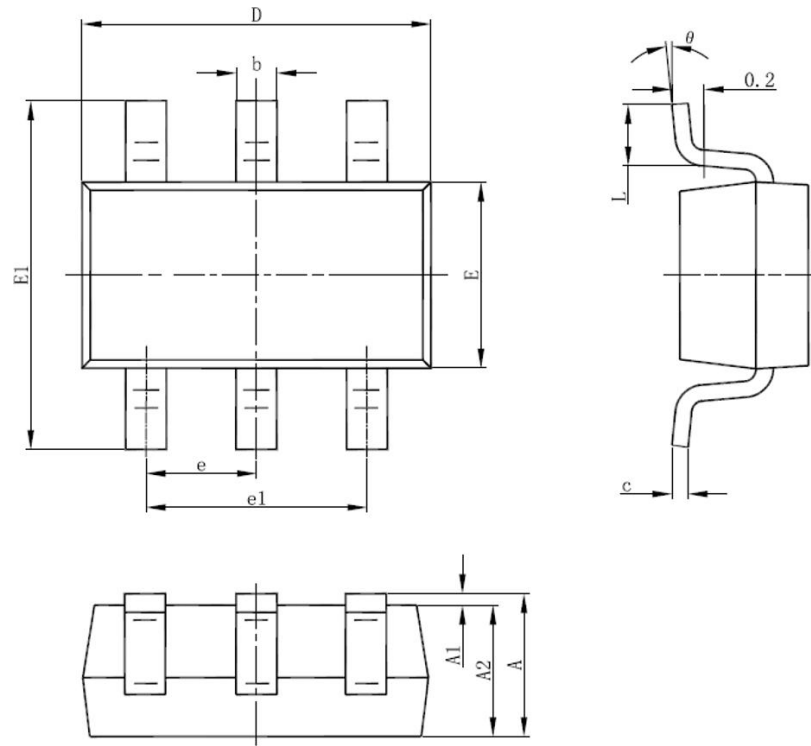

SYMBOL	MILLIMETE		
	MIN	NO	MA
A	-	-	1.35
A1	0.0 4	-	0.15
A2	1.0 0	1.10	1.20
b	0.3	0.4	0.5
c	0.1	0.15	0.2
D	2.7 2	2.92	3.12
E	1.4 0	1.60	1.80
E1	2.6 0	2.80	3.0
e	0.95BSC		
e1	1.90BSC		
L	0.3 0	-	0.60
θ	0	-	8°